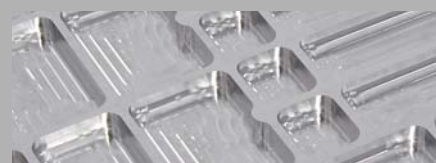
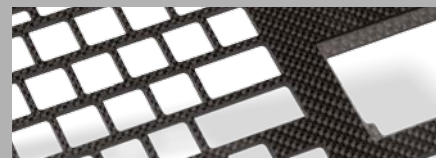
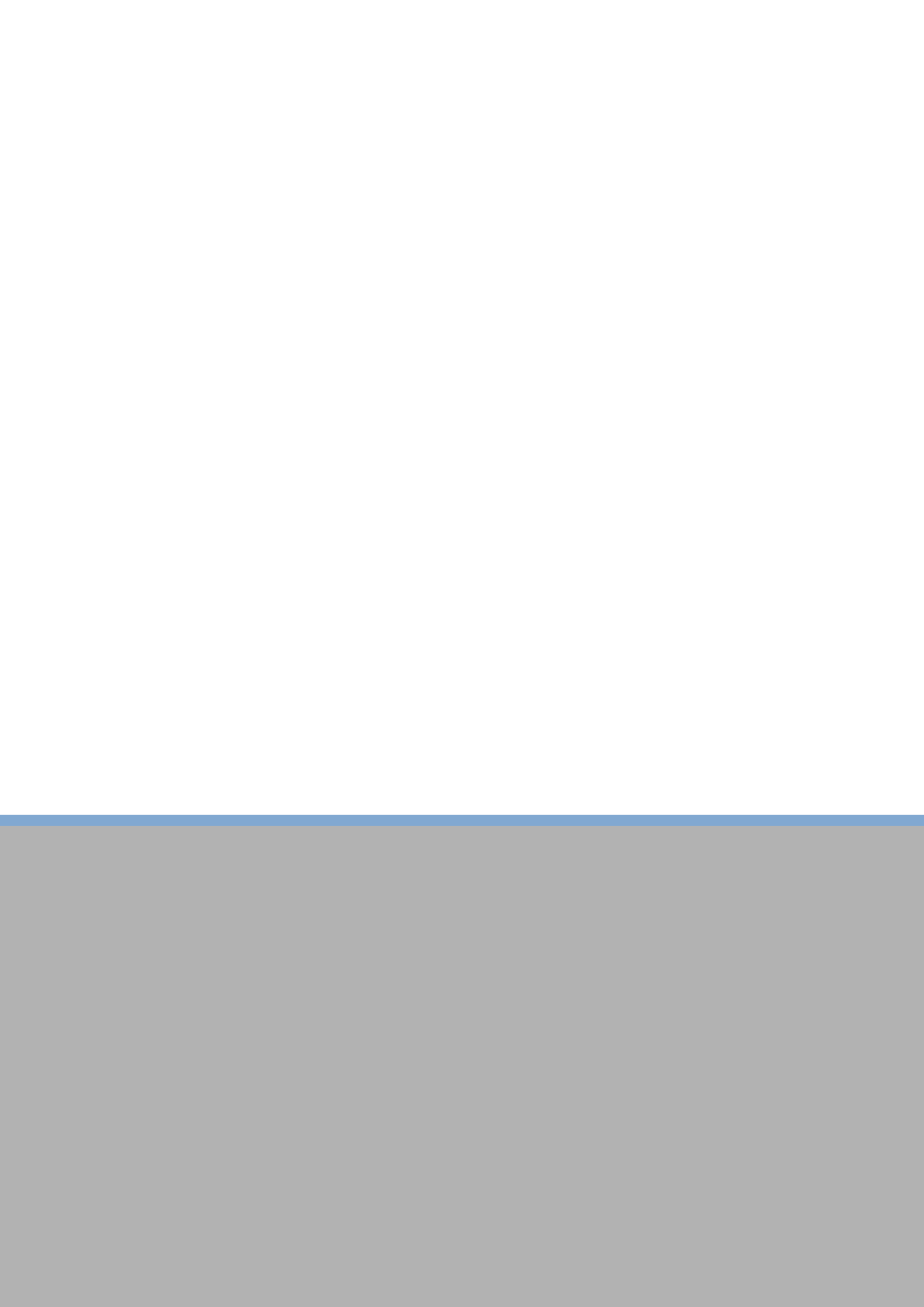




## DATRON Portal and 5-axis CNC Milling Machines

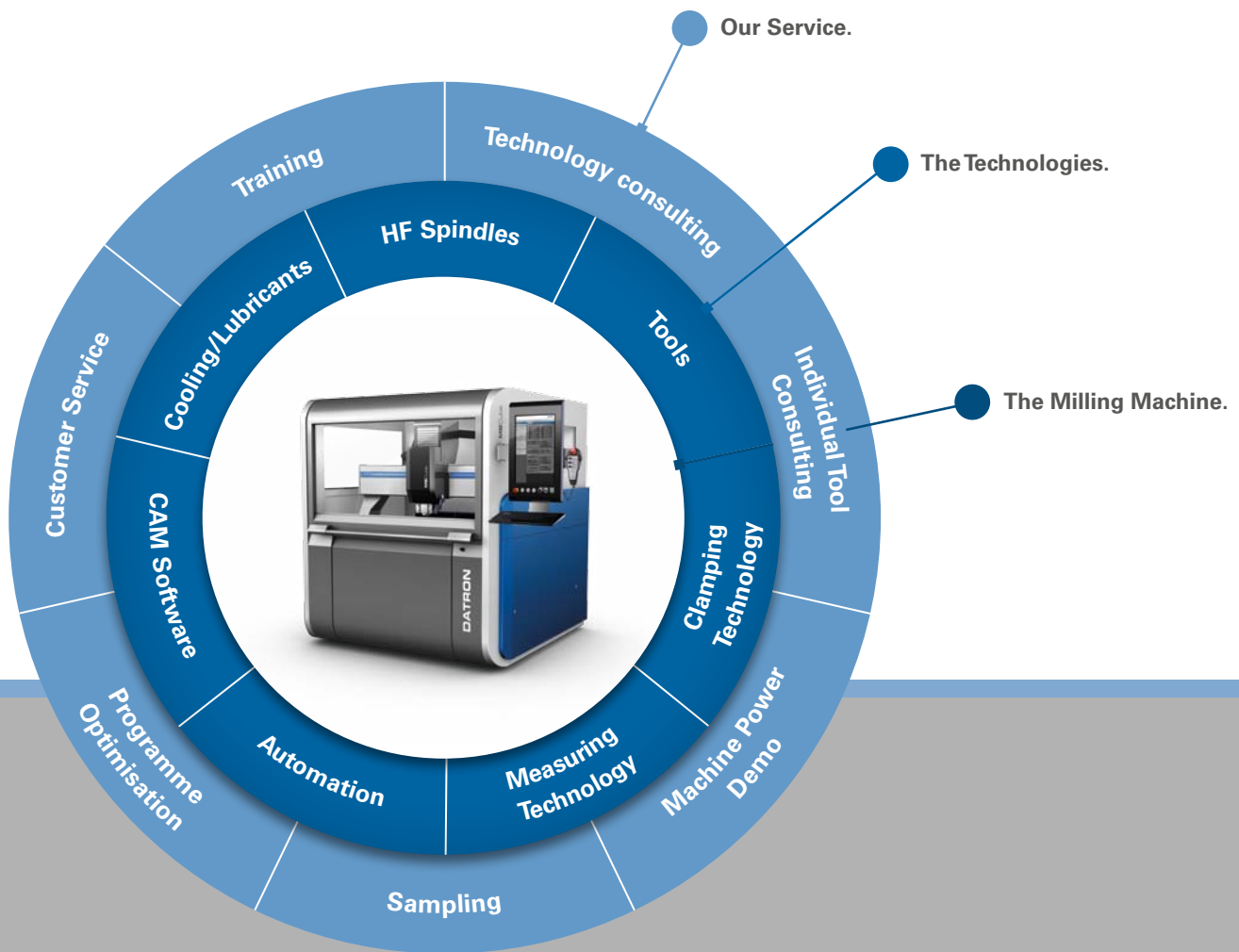
Machining of large and small components,  
in small or large volumes, with speeds  
up to 60,000 rpm





More than just machine construction –  
**Absolutely everything from  
DATRON's expert hands**

We at DATRON see ourselves as your partner for successful production. Our service: everything from one source. DATRON offers not only cutting-edge machine construction with "Made in Germany" solidity and reliability: we accompany you through the entire workflow from technology consulting over the sales process, optimal maintenance and repair services up to training and give you tips for energy-saving and cost-reducing production.



# Optimised for Small Tools –

yet solid and precise!

## High-speed CNC milling with high quality and short production times

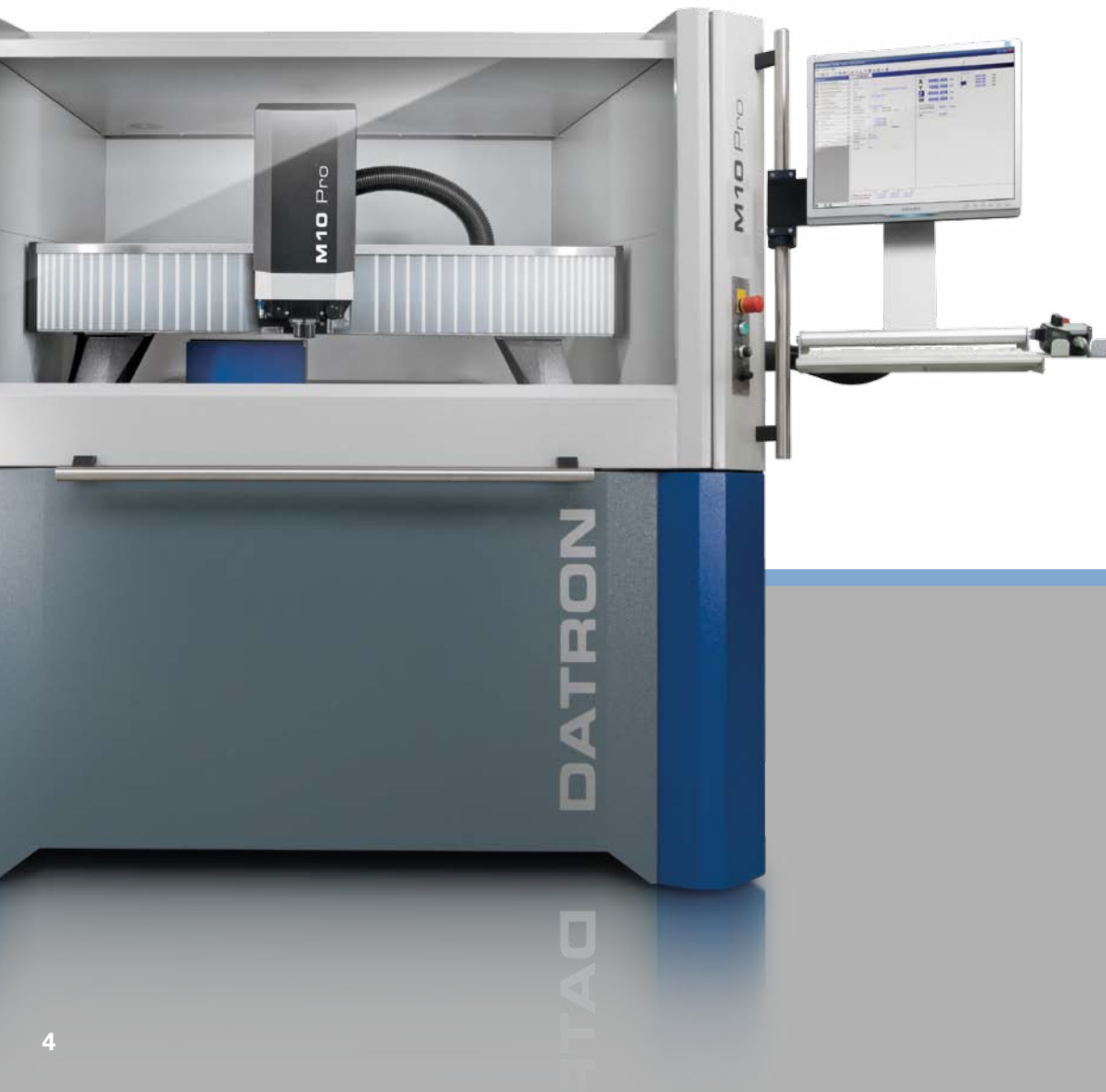
DATRON milling machines provide highest precision and surface quality at an excellent price-performance ratio. From 3-axis to 5-axis simultaneous machining: we offer tailor-made solutions for individual needs. Tools and accessories perfectly matched to our machines guarantee highest efficiency and cost-effectiveness.

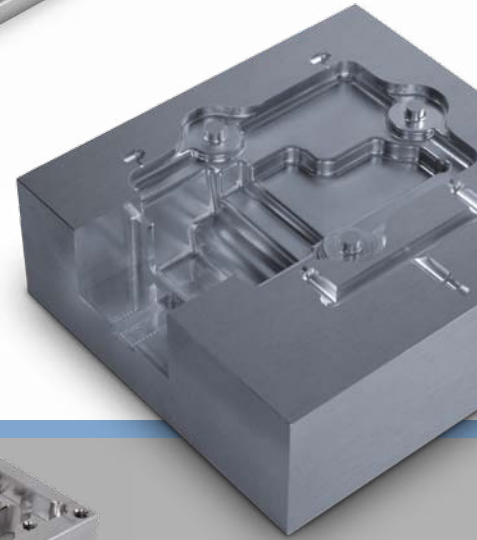
### Their features at a glance:

- High-speed spindles, up to 60,000 rpm
- Short setup times due to DATRON clamping fixtures
- Flexible module clamping solutions
- Minimum quantity cooling/lubrication system
- Automatic tool changer
- Proprietary tool technology for high-speed machining
- Easy and quick programming
- Microsoft Windows-based control
- Optional automation solutions
- Very low energy consumption

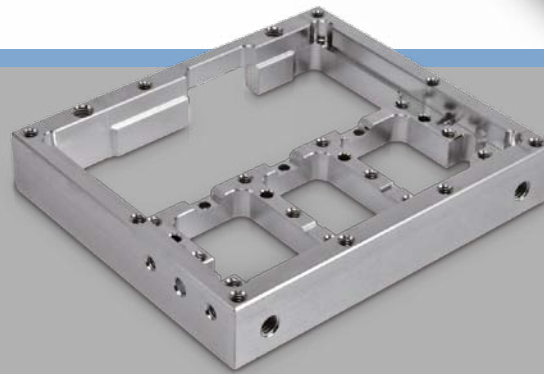
Custom tool development is also possible.

Our milling machines are complemented with a comprehensive range of services: expert application advice and customer-specific sample machining at our Technology Centre, product training and after-sales service solutions





Whether micron-precise or cost-effective and versatile –  
**DATRON has the solution!**



**Examples for applications:**

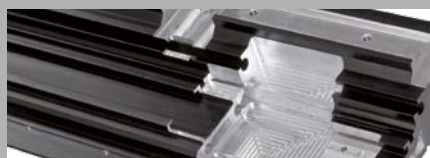
- Front panels
- Housings
- 3D-engraving and stamps
- Electrode production
- Prototypes
- Technical components
- 5-axis machining
- and many more

**Materials:**

- Aluminium
- Nonferrous metals
- Steel (alloys)
- Plastics
- Composite materials (GRP, CRP, etc.)
- Graphite
- and many more

**Industries:**

- Electronics industry
- Medical technology
- Tool and mould construction
- Automotive industry
- Prototypes
- Aerospace
- Watch and jewellery industry
- Advertising
- and many more



# DATRON

## Machine Overview

Every application is specific and we provide the perfect solution for your specific needs: Whether 3, 3+2 or 5 axis simultaneous, high-precision or especially cost-effective machining. Our experts will be happy to advise and help you to find the most effective solution for your application.

### Powerful and highly accurate

#### DATRON M10 Pro

Further information on pages 8–9



### Productive and versatile

#### DATRON M8Cube

Further information on pages 10–11



### Large-sized and efficient

#### DATRON MLCube

Further information on pages 12–13



## Compact and cost-effective

DATRON M7  
DATRON M75

Further information on pages 14–15



## 5-axis, precise and compact

DATRON C5  
DATRON D5

Further information on pages 16–17

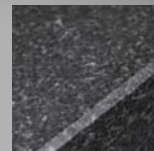
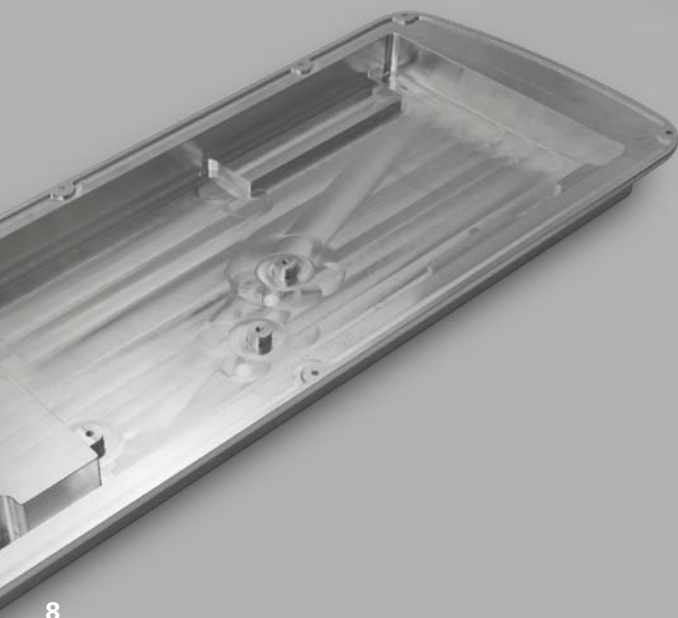


# DATRON M10 Pro

## Productive – Precise – Powerful

Varying lot sizes, small numbers of high-tech materials: with the DATRON M10 Pro you adjust very quickly to new demands. Productive and cost-effective starting from the first unit! The integrated linear measuring system with a resolution of 40 nm guarantees precision durability.

Integrated micron-accurate linear measuring system!



Solid, temperatur-stable **granite table** with extremely high levelness.

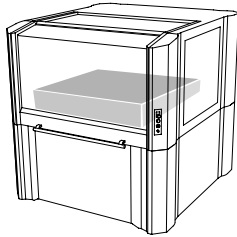
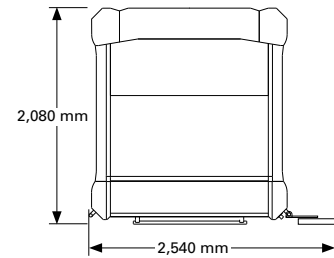
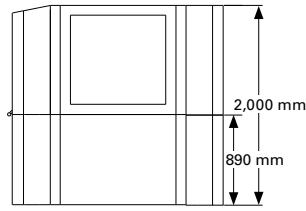
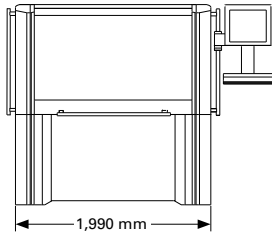


**5-axis milling with rotary/swivel table** for precise multi-sided machining of small pieces (optional).



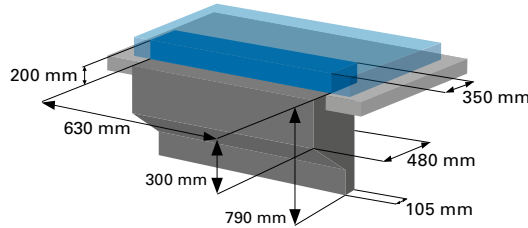
Integrated **zero-point clamping system** with  $\pm 5 \mu\text{m}$  repeatability (optional).



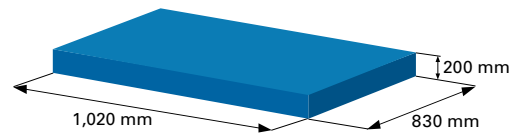


**Table with cut-out:**

- Table
- Machining area within the vertical clamping area
- Maximum workpiece size



**Full Table:**  
Machining area



Technical Data	M10 Pro	M10 Pro+ with encapsulated linear position measuring system in all axes
Machining table	Solid Granite table with Steel column, extremely rigid portal design with double-sided Y drive with covered guides	
Traverse path (X x Y x Z)	1,020 mm x 830 mm x 240 mm; with tool changer 720 mm in Y	
Portal passage	200 mm	
Installation dimensions without operating terminal (W x D x H)	1,990 mm x 2,080 mm x 2,000 mm	
Conical holding fixture integrated into table		✓
Integrated zero-point clamping system		optional
Fast digital servo control with Microsoft® Windows® control computer		✓
Easy-to-use hand-held control unit		✓
Drive system: Digital servo drives; ball-screw for every axis		✓
Linear position measuring system in all axes	-	✓
Chip conveyor		optional
Minimum quantity lubrication		✓
Machining spindle	Precision-PowerS Syncro 3.0 kW HF spindle, up to 40,000 rpm	
Tool changer with integrated tool length sensor	11 tools with HSK-E 25 tool holding fixture (optional for 22 tools)	
Feed	up to 30 m/min	
Positioning feed	up to 30 m/min	
Weight	approx. 2 t	
<b>Article Number</b>	<b>0A01015A</b> (with cut-out) <b>0A01015B</b>	<b>0A01016A</b> (with cut-out) <b>0A01016B</b>

**The M10 Pro CNC milling machine offers in its basic version:**

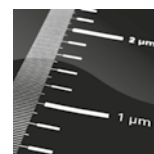
- Machining table made of solid Granite/Steel with a Steel protective cover
- New, highly dynamic 3D CNC control for three to six axes
- 19" LCD-Monitor 19" with Microsoft® Windows® control computer
- Network and USB interface for data exchange
- Menu-guided CNC programming software DATRON HSCpro



**40,000 rpm** – High cutting performance with small tools. High dynamic HSC control system.



**Precision spindle** with a concentricity better 2 µm and HSK-E 25 tool holding fixture.



**Optical linear position measuring system** with ± 5 µm absolute accuracy and 40 nm accuracy (optional).

# DATRON M8Cube

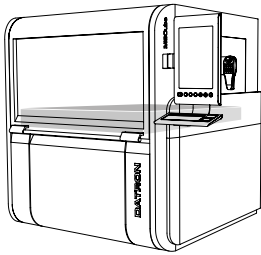
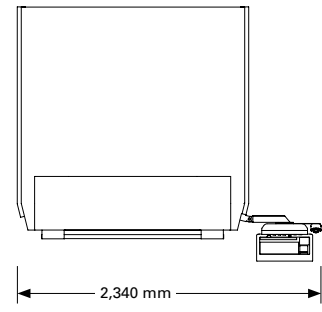
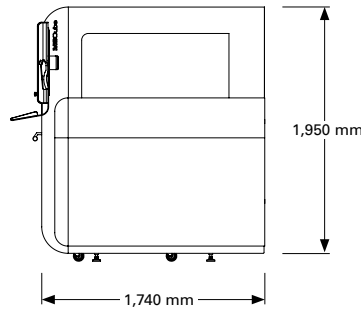
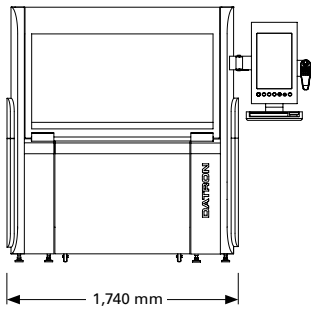
The DATRON M8Cube is the best choice for efficient machining of housings, profiles and panels made of aluminium.

But other nonferrous metals or composite materials can also be machined most efficiently with the M8Cube. Short setup times, very low power consumption and excellent value for money allow high cost-effectiveness, even at low volumes.

## Your benefits at a glance:

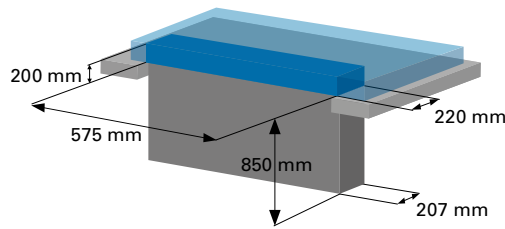
- **You save space!**  
Very large machining surface with a small footprint.
- **You save money!**  
The M8Cube is accessible to buy and has extremely low acquisition and operating costs.
- **You get new opportunities in milling, drilling and engraving!** The M8Cube has been developed for machining high-tech materials with small tools ( $\varnothing$  0.1 mm to 20 mm). Innovative „Made in Germany“ milling technology for your success.



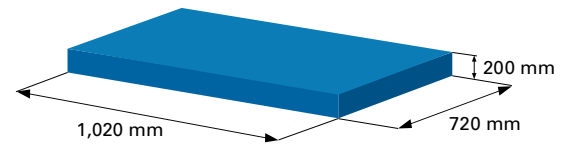


**Table with cut-out:**

- Table
- Machining area within the vertical clamping area
- Maximum workpiece size



**Full Table:**  
Machining area



Technical Data	DATRON M8Cube	
Machine table	Solid Polymer concrete table with Steel column, extremely rigid portal design with double-sided Y drive with covered guides	
Traverse path (X x Y x Z)	1,020 mm x 830 mm x 245 mm; with tool changer 720 mm in Y	
Portal passage	200 mm	
Installation dimensions without operating terminal (W x D x H)	1,740 mm x 1,740 mm x 1,950 mm	
Conical holding fixture integrated into the table	✓	
Fast digital servo control with Microsoft® Windows® control computer	✓	
Easy-to-use hand-held control unit	✓	
Drive system: Brushless servo motors with absolute encoders, ball-screw spindle for each axis	✓	
Minimal quantity lubrication	✓	
Machining spindle	Precision high-frequency spindles from 0.6 kW to 3.0 kW with up to 60,000 rpm	
Tool changer with integrated tool length sensor	5-fold tool changer with HSK-E 25 (optional 10-fold), 15-fold tool changer with direct shank (optional 30-fold)	
Feed	up to 22 m/min	
Positioning feed	up to 22 m/min	
Weight	approx. 1,300 kg	
Article Number	0A03200A (with cut-out)	0A03200B



**Status display** by means of signal LEDs integrated into the operating terminal and the portal to display machine status (optional).



**Precision spindle** with a concentricity better 2 µm and HSK-E 25 tool holding fixture (optional).



**XYZ measuring system** integrates measuring functions and foolproof material tolerance compensation (optional).



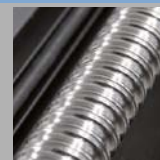
**Saves resources:** Minimum quantity lubrication from 30 ml/hour. Minimal cleaning costs (optional).



**Up to 60,000 rpm:** High cutting performance with small tools. High dynamic HSC control system.



**5-axis milling with rotary/swivel table** for precise multi-sided machining of small parts (optional).



**Precision ball-screw spindles** and linear guides from leading suppliers. Brushless direct drives in the X/Y-axes.

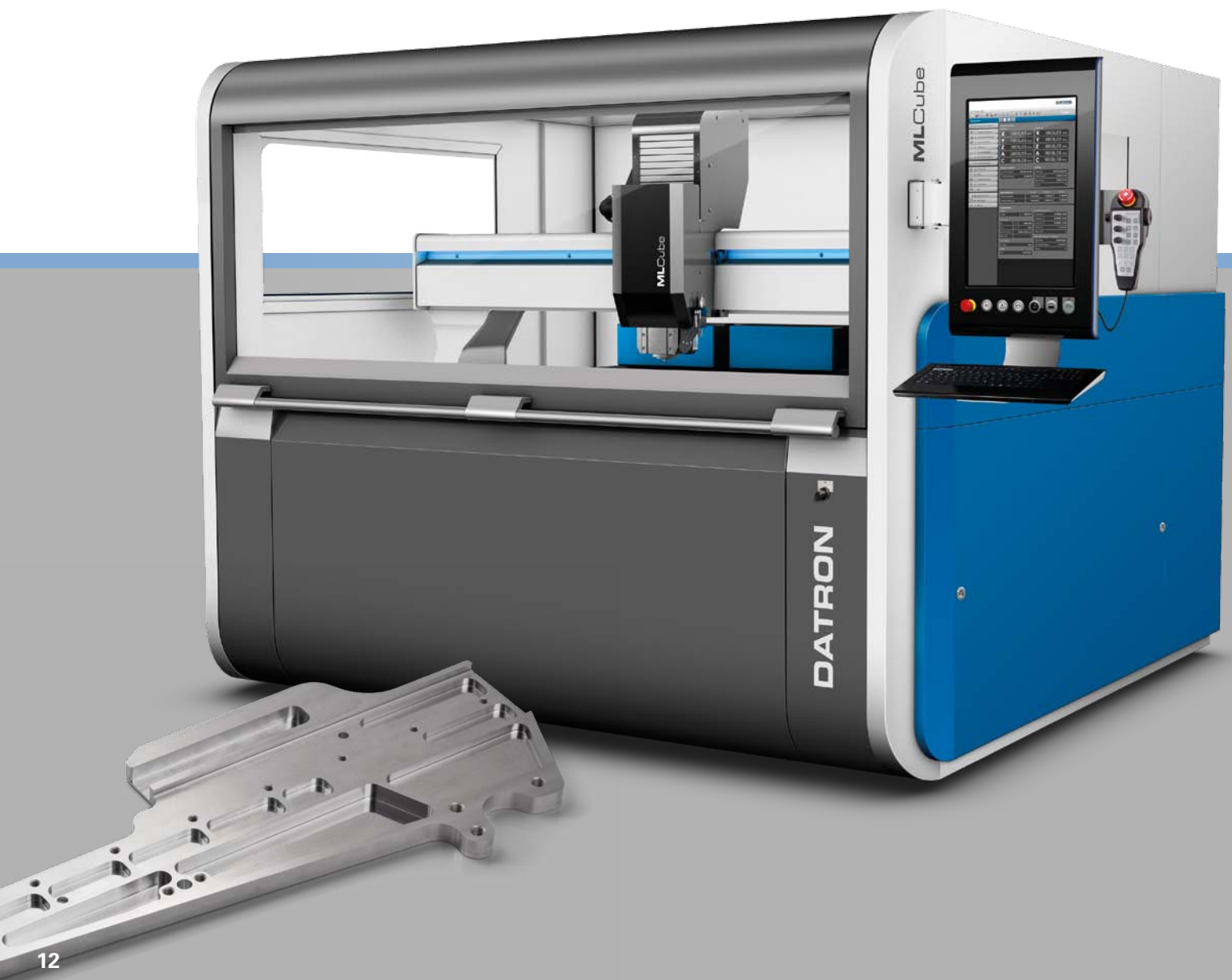
# DATRON MLCube

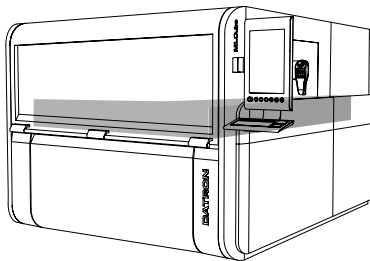
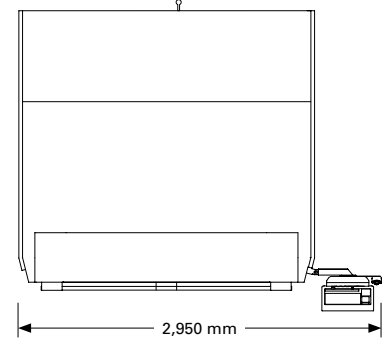
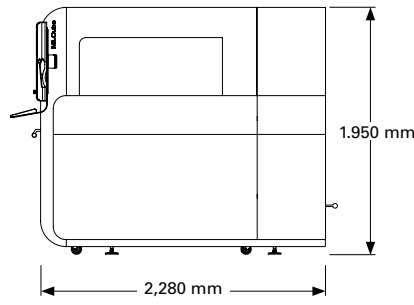
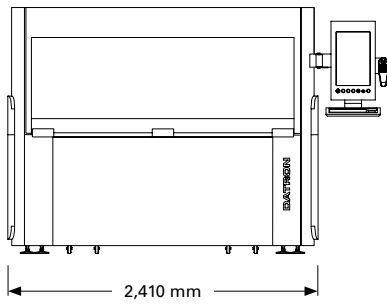
The DATRON MLCube is the best choice for cost-effective sheet machining, for example, for the production of front panels, housings, profiles and other aluminium workpieces milled in nested form.

Other non-ferrous metals or composite materials can also be processed most efficiently with the MLCube. Its short setup times and its ability to use different clamping techniques simultaneously, its very low power consumption and its excellent price-performance ratio – even for low production volumes – provide long-term and extremely high profitability.

- **High dynamics** through optimised control and mechanical construction designed for acceleration and rigidity

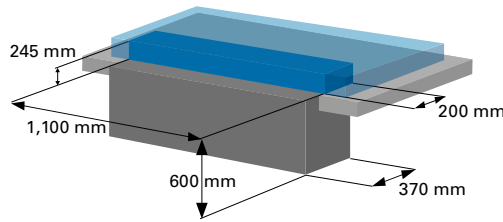
- **Very high clamping performances** with the smallest tools by means of high-speed precision spindles with up to 60,000 rpm and 0.6 kW to 3.0 kW output
- **Stiff, vibration-free design** of the machine allows excellent surface finishes when machining
- **High precision** due to high-quality linear guides, ball screw spindles, HSK-E 25 tool inserts (optional) and precision-crafted structural elements
- **New electrically switchable vacuum technology** allows working flexibly and cost-effectively due to very short set-up times (imminent connection upon placement of vacuum plate)



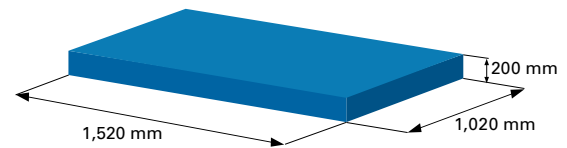


**Table with cut-out:**

- Table
- Machining area within the vertical clamping area
- Maximum workpiece size



**Full Table:**  
Machining area



Technical Data	DATRON MLCube	
Machine table	Solid Polymer concrete table with Steel column, extremely rigid portal design with double-sided Y drive with covered guides	
Traverse path (X x Y x Z)	1,520 mm x 1,150 mm x 245 mm; with tool changer 1,020 mm in Y	
Portal passage	200 mm	
Installation dimensions without operating terminal (W x D x H)	2,410 mm x 2,280 mm x 1,950 mm	
Conical holding fixture integrated into the table	✓	
Fast digital servo control with Microsoft® Windows® control computer	✓	
Easy-to-use hand-held control unit	✓	
Drive system: Brushless servo motors with absolute encoders, ball-screw spindle for each axis	✓	
Minimal quantity lubrication	✓	
Machining spindle	Precision high-frequency spindles from 0.6 kW to 3.0 kW with up to 60,000 rpm	
Tool changer with integrated tool length sensor	5-fold tool changer with HSK-E 25 (up to 36-fold) 15-fold tool changer with direct shank (up to 45-fold)	
Feed	up to 22 m/min	
Positioning feed	up to 22 m/min	
Weight	approx. 2,500 kg	
Article Number	0A03300A (with cut-out)	0A03300B



**Status display** by means of signal LEDs integrated into the operating terminal and the portal to display machine status (optional).



**Precision spindle** with a concentricity better 2 μm and HSK-E 25 tool holding fixture (optional).



**XYZ measuring system** integrated: Measuring functions and very easy-to-use material/tolerance compensation (optional).



**Saves resources:** Minimum quantity lubrication from 30 ml/hour. Minimal cleaning costs (optional).



**Up to 60,000 rpm:** High cutting performance with small tools. High dynamic HSC control system.



**Precision ball-screw spindles** and linear guides from leading suppliers. Brushless direct drives in the X/Y-axes.



**Tool changer** allows flexible implementation of the most diverse milling applications.

# DATRON M7/M75

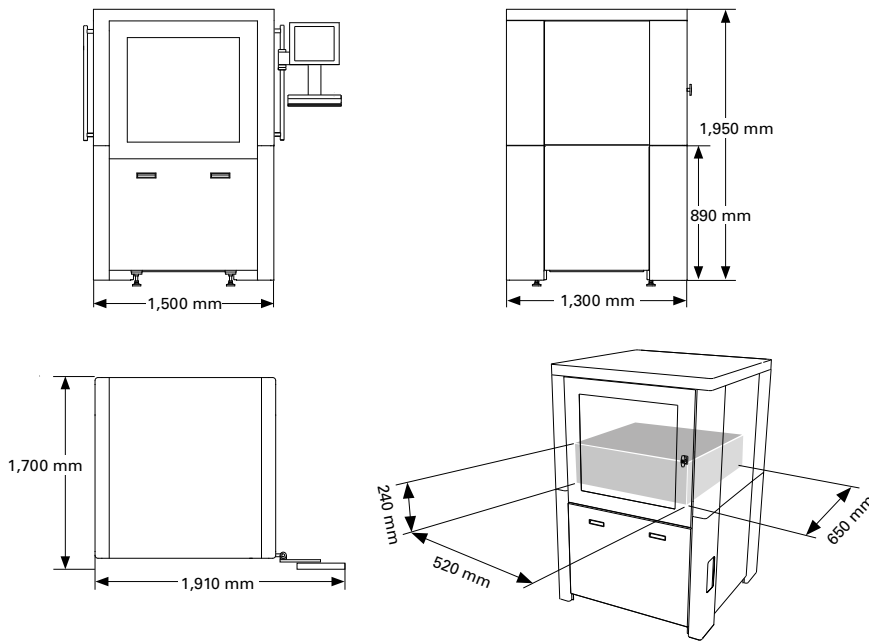
## Compact and cost-effective

The DATRON M7/M75 milling machines considerably improve the manufacturing speed and quality when small tools are used. With a very small floor space this compact machine offers maximum traverse paths. The solid granite construction allows highly dynamic CNC machining and, at the same time, ensures a high surface quality.

- Traverse path (X x Y x Z):  
520 mm x 650 mm x 240 mm;  
(with tool changer useable in Y 520 mm)

- Floor space (W x D): 1,500 mm x 1,300 mm
- High precision due to compact design and granite table
- Precision high-frequency spindles from 0.6 kW up to 3.0 kW with speeds up to 60,000 rpm; for series M75: 1.2 kW HF spindle with speeds up to 30,000 rpm
- Efficient machining of small CNC parts
- 3D rapid prototyping, 3D engraving





Technical Data	DATRON M7/M75
Machine table	Massive Granite table on a Steel frame structure with double-portal-Y-drive
Traverse path (X x Y x Z)	520 mm x 650 mm x 240 mm; with tool changer 520 mm in Y
Portal passage	200 mm
Installation dimensions without operating terminal (W x D x H)	1,500 mm x 1,300 mm x 1,950 mm
Conical holding fixture integrated into the table	✓
Fast digital servo control with Microsoft® Windows® control computer	✓
Easy-to-use hand-held control unit	✓
Drive system: Brushless servo motors with absolute encoders, ball-screw spindle for each axis	✓
Minimal quantity lubrication	✓
Machining spindle	HF spindles 0.6 kW and 3.0 kW with speeds up to 60,000 rpm
Tool changer with integrated tool length sensor	maximum 15-fold
Feed	up to 16 m/min
Positioning feed	up to 16 m/min
Weight	approx. 800 kg
Article Number	0A01191



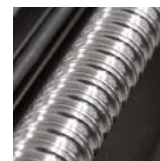
**XYZ measuring system** integrated: Measuring functions and very easy-to-use material/tolerance compensation (optional).



**Saves resources:** Minimum quantity lubrication from 30 ml/hour. Minimal cleaning costs (optional).



**Up to 60,000 rpm:** High cutting performance with small tools. High dynamic HSC control system.



**Precision ball-screw spindles** and linear guides from leading suppliers. Brushless direct drives in the X/Y-axes.



**Tool changer** allows flexible implementation of the most diverse milling applications.

# DATRON C5

## How were precise small components manufactured before the C5 existed?

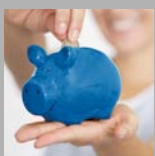
You will probably ask yourself this question when you see this high-tech machine in action. Ultra-compact, ultra-precise. "Yes, this is a high precision 5-axis milling machine of a new class". The experts are amazed and we are also a little proud of this "miracle" of the art of engineering.



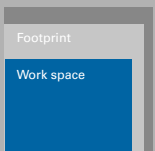
**Saves resources:**  
Minimum quantity lubrication from 30 ml/hour. Minimal cleaning costs.



**Energy-saving:**  
Very low power consumption protects the environment and your purse.



**Saves money:**  
Low-cost in purchase and operation.



**Ultra compact, solid, precise.**  
No other high-tech 5-axis milling machine of this class takes up so little space.



## DATRON D5

Dental CAD/CAM milling/grinding machine  
For the five-axis simultaneous machining  
of all current materials

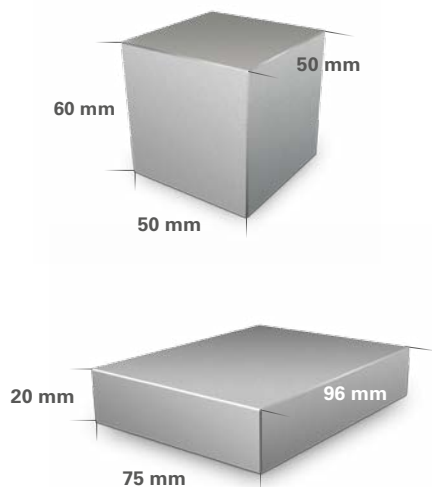
Further information: [www.dentalcam.com](http://www.dentalcam.com)



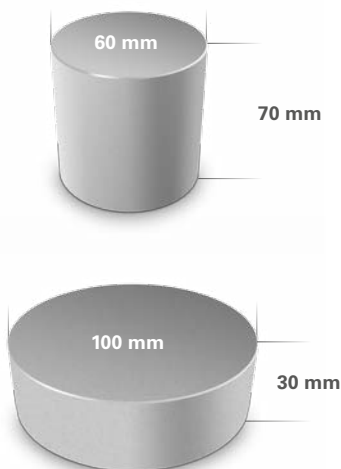


Examples of workpiece sizes:

Cubic components



Cylindrical components



The 5-axis milling machine C5 in its basic configuration provides:

- 1.8 kW precision spindle with HSK-E 25 tool holder, up to 48,000 rpm
- High precision 4th/5th axis
- Automatic 22fold tool changer
- Integrated tool length sensor
- Heidenhain linear measuring system on all axes
- Optional zero-point clamping systems:
  - Zero Clamp
  - Polygrip for Erowa ITS 50 and 3R Macro
  - Defo Grip for workpiece direct clamping
- Programme driven minimum quantity cooling lubrication system
- Integrated camera (optional)

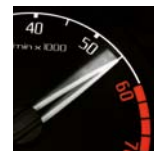
Technical Data	DATRON C5
<b>Working area</b>	
Traverse path (X x Y x Z)	153 mm x 100 mm x 100 mm
Workpiece sizes (Examples)	<b>Cylindrical:</b> Diameter 60 mm, height 70 mm Diameter 100 mm, height 30 mm <b>Cubic (X x Y x Z):</b> 96 mm x 75 mm x 20 mm 50 mm x 50 mm x 60 mm
Tool length	75 mm (from HSK face contact)
<b>Machine dimensions</b>	
Machine construction	Solid cast steel frame, 4th/5th axis made of cast aluminium
Installation dimensions (W x D x H) without control unit	940 mm x 1,190 mm x 1910 mm
Weight	ca. 900 kg
<b>Supply</b>	
Voltage	3 x 400 VAC/16A
Power input	4,000 VA (max. fuse 3 x 16 A)
Air connection	7 - 10 bar, dry, clean, oil-free
Ambient temperature	15 - 30 °C
Machine housing	Compact cabin with easy access for comfortable maintenance
USB interface	✓
Ethernet interface	✓
Convenient manual control panel	✓
Minimal quantity lubrication	✓
Built-in zero-point clamping system	✓
Linear positioning measuring system on all axes	✓ Resolution 5 nm
Tool changer	22fold with tool length sensor
Machining spindle	1,8 kW, up to 48,000 rpm with HSK-E 25 tool holder
<b>Article Number</b>	<b>0A03010</b>



**Status display** by means of signal LEDs integrated into the operating terminal to display machine status.



**Integrated clamping system for electrodes Polygrip** for EROWA ITS 50 and 3R Macro (optional)



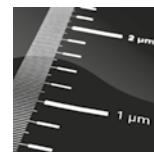
**48,000 rpm**  
High milling performance with small tools. High dynamic HSC control system.



**Precision spindle** with a concentricity better 2 µm and HSK-E 25 tool holding fixture.



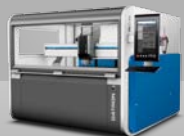




Integrated **zero-point clamping system** with ± 0,5 µm repeatability (optional).



**Optical linear position measuring system** with ± 5 nm resolution

# Machines that Fit Your Production Task!

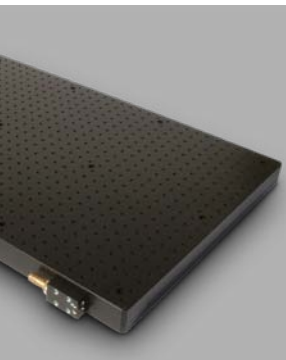
	M10Pro	M8Cube	MLCube	M7/M75	C5
					
<b>Traverse path (X x Y)*</b>	1,020 mm x 830 mm Z stroke = 240 mm	1,020 mm x 830 mm Z stroke = 245 mm	1,520 mm x 1,150 mm Z stroke = 245 mm	520 mm x 650 mm Z stroke = 240 mm	153 mm x 100 mm Z stroke = 100 mm
<b>Spindle power</b>	Precision PowerS Syncro 3.0 kW HF spindle, up to 40,000 rpm, HSK-E 25	0.6 kW - 3.0 kW according to type 60,000 rpm, direct shaft or HSK-E 25	0.6 kW - 3.0 kW according to type 60,000 rpm, direct shaft or HSK-E 25	0.6 kW - 3.0 kW according to type 60,000 rpm, direct shaft or HSK-E 25	1.8 kW up to 48,000 rpm, HSK-E 25
<b>Feed/ Positioning Feed</b>	up to 30 m/min	up to 22 m/min	up to 20 m/min	up to 16 m/min	up to 8 m/min 21 min <sup>-1</sup>
<b>Main applications</b>	<ul style="list-style-type: none"> <li>- High-performance machining</li> <li>- Precision machining</li> <li>- Thicker materials</li> <li>- Small serial production</li> <li>- Panel production</li> <li>- Panel materials</li> </ul>	<ul style="list-style-type: none"> <li>- High-performance machining</li> <li>- Small serial production</li> <li>- Panel production</li> <li>- Panel materials</li> <li>- Thicker materials</li> </ul>	<ul style="list-style-type: none"> <li>- Small serial production</li> <li>- Panel production</li> <li>- Panel materials</li> </ul>	<ul style="list-style-type: none"> <li>- Small serial production</li> <li>- Panel production</li> <li>- Panel materials</li> </ul>	<ul style="list-style-type: none"> <li>- 5-axis machining</li> <li>- Precision engineering</li> <li>- Electrode production</li> <li>- Watches</li> <li>- Jewellery industry</li> <li>- Micro machining</li> <li>- Medical technology</li> </ul>

\* Can be limited between 100 mm and 200 mm by a tool changer in Y direction.

# Innovations That Make You Even More Successful!

## Clamping Technology

Whether pneumatic or vacuum clamping technology: DATRON's systems distinguish themselves by their high flexibility, high ease of use and short changeover times.



## Measuring Technology

The XYZ sensor guarantees short setup times and increased accuracy and efficiency by automatically determining the reference edges and measuring the height profile.



## Cooling/Lubrication System

Ecologically and economically optimised processes with minimum quantity cooling lubrication and longer tool life associated with it.



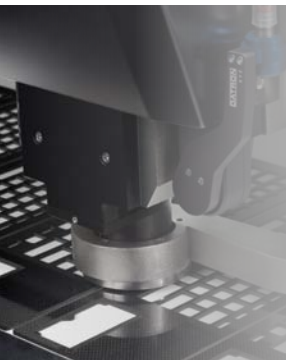
## HF Spindels

For milling tools less than 0.1 mm - but also high clamping performances with milling heads up to 20 mm. DATRON's precise and durable high-frequency spindles will convince you.



## Suction - CleanCut

Almost chip-free work due to highly effective chip suction. A must for plastics such as GRP and CRP; an advantage for many metal-machining applications.



## CNC Milling Tools

High cutting and rotation speeds require special tools. Many years of research and experience have been placed inside DATRON tools: profit by them!



## DATRON Machine Software

The "DATRON CNCv9" machine software offers convenient functionality for quick setup and CNC programming and acquisitions 3D CNC files of any size.



## CAM Software

With DIN/ISO standard interfaces, DATRON machines are compatible with all popular 3D-CAD/CAM programs, such as Mastercam, Type3, SolidCAM or Pro/E.



DATRON

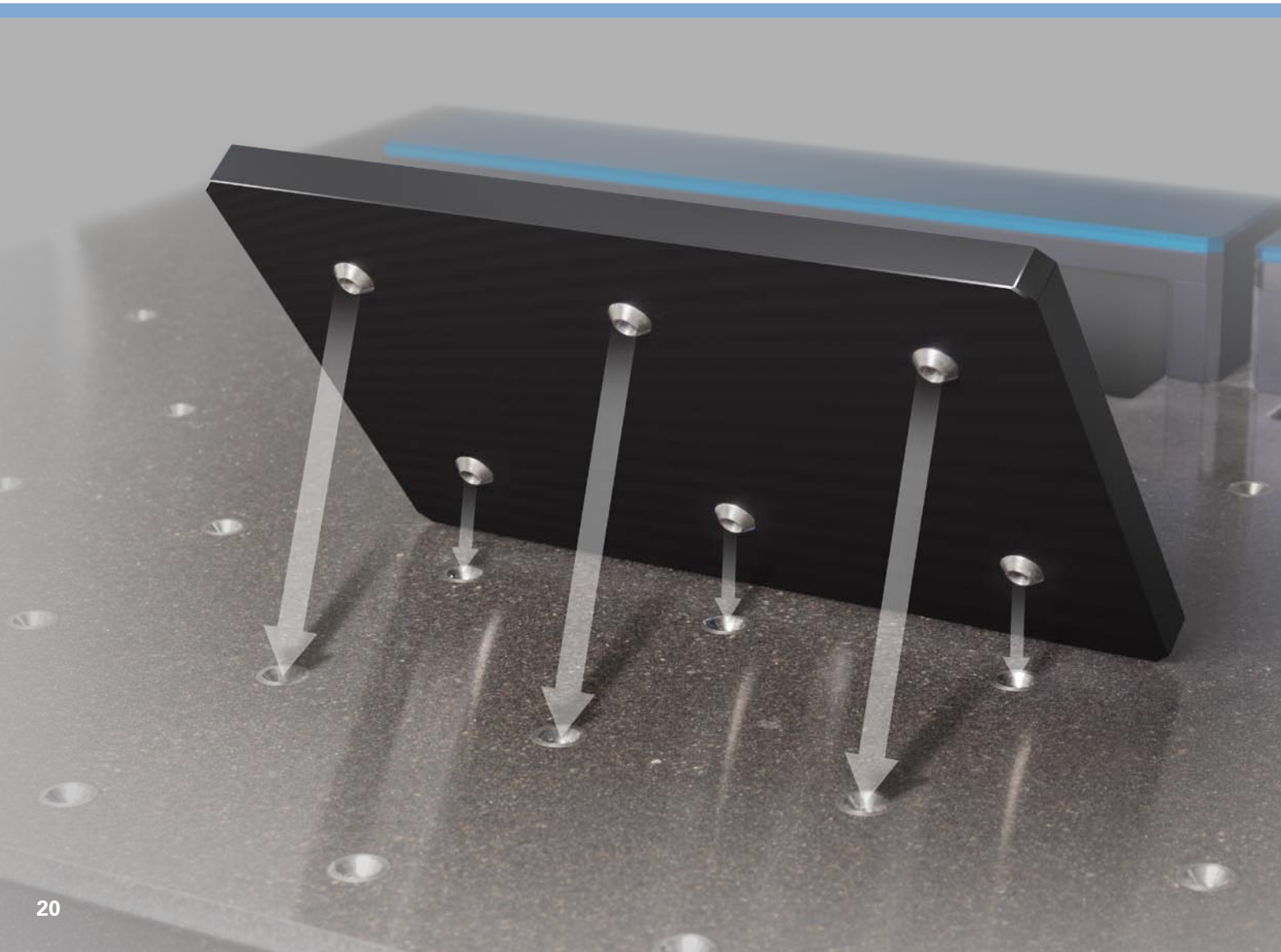
## Module Clamping Technology

The end of tedious and long screwing and setup times!

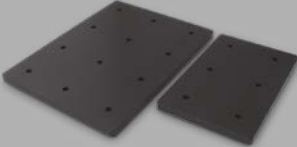

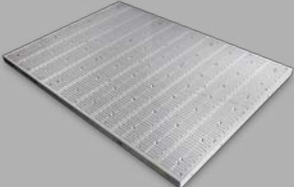


**Cost-effective production by clamping within seconds:**

Setup times can be often reduced significantly with DATRON's modular clamping technology. The module plates are clamped directly onto the machine table using conical centring sleeves. This applies to all machines with integrated cone clamping systems and allows very fast changing of clamping modules. Clamping position reproducibility is only a few hundredths of a millimetre.

DATRON offers a variety of ready-made module clamping solutions: module clamping plates with vacuum, T-slots with short-stroke clamping elements, clamping chucks or vices. We will also be happy to design the custom clamping solutions you may need. Benefit from our experience of hundreds of machines installed.





Module Clamping Technology	Description
<p>Module clamping plates</p> 	<p>Clamping elements such as vices can be fastened onto the module clamping plates. The modules are fastened to the machine table by screwing. Recurrent clamping stations can be installed on these base plates and set up when required.</p>
<p>T-slot module clamping plates e. g. for short-stroke clamps</p> 	<p>T-slot module clamping plates offer room for application-specific clamping solutions or the combination of short-stroke clamping elements and fixed clamping jaws. The modules are mounted onto the machine table either by screwing or by vacuum suction.</p>
<p>Plates with meandering grooves</p> 	<p>DATRON's plates with meandering grooves are particularly suitable for clamping flat workpieces and sheet materials. It allows clamping several similar or different workpieces at the same time. DATRON's VacuCard™ special cardboard is used to distribute vacuum under the workpiece and as sacrificial layer. Plates with meandering grooves are available in different sizes.</p>
<p>DATRON Compact centric clamps and multifunctional clamps</p> 	<p>Encapsulated DATRON compact centric clamps are 100% protected against soiling. Due to their especially developed slider geometry with a guide length of 150 mm, they are the first fully encapsulated compact centric clamps. Malfunctions due to soiling and jammed chips are something of the past.</p>
<p>Rotary axis with tailstock</p> 	<p>The rotary axis is particularly suitable for multi sided machining of long workpieces, for circular engravings or for drilling in radial direction. Clamping is done using DATRON's module clamping technique, allowing a variable clamping length. The rotary axis is impact-free and provides high precision and torsional stiffness.</p>

DATRON

# Vacuum Clamping Technology

It can't be clamped? – Not any more!

**Even the smallest pieces can be clamped using the high clamping forces of DATRON's vacuum plates. The patented VacuCard++ special cardboard is the perfect sacrificial layer. Extremely simple and easy to use. Just set up the pieces and... you are done!**

All DATRON machines can be equipped with DATRON's vacuum clamping technology. It allows very high clamping forces due to its especially developed construction, even in case of shapes and thinnest plate materials difficult to clamp otherwise. Module vacuum clamping plates, available in different sizes, are divided into segments which can be operated separately from each other with a vacuum distributor. Several different workpieces can also be clamped simultaneously.

Time-efficient optimum utilization machining, which allows manufacturing several individual pieces from a single plate, is also possible thanks to the vacuum clamping technology. Highest machine utilization can also be achieved this way.

DATRON's VacuCard special cardboard is used to distribute the vacuum below the workpiece and as a sacrificial layer, allowing complete milling around workpieces and separating them.

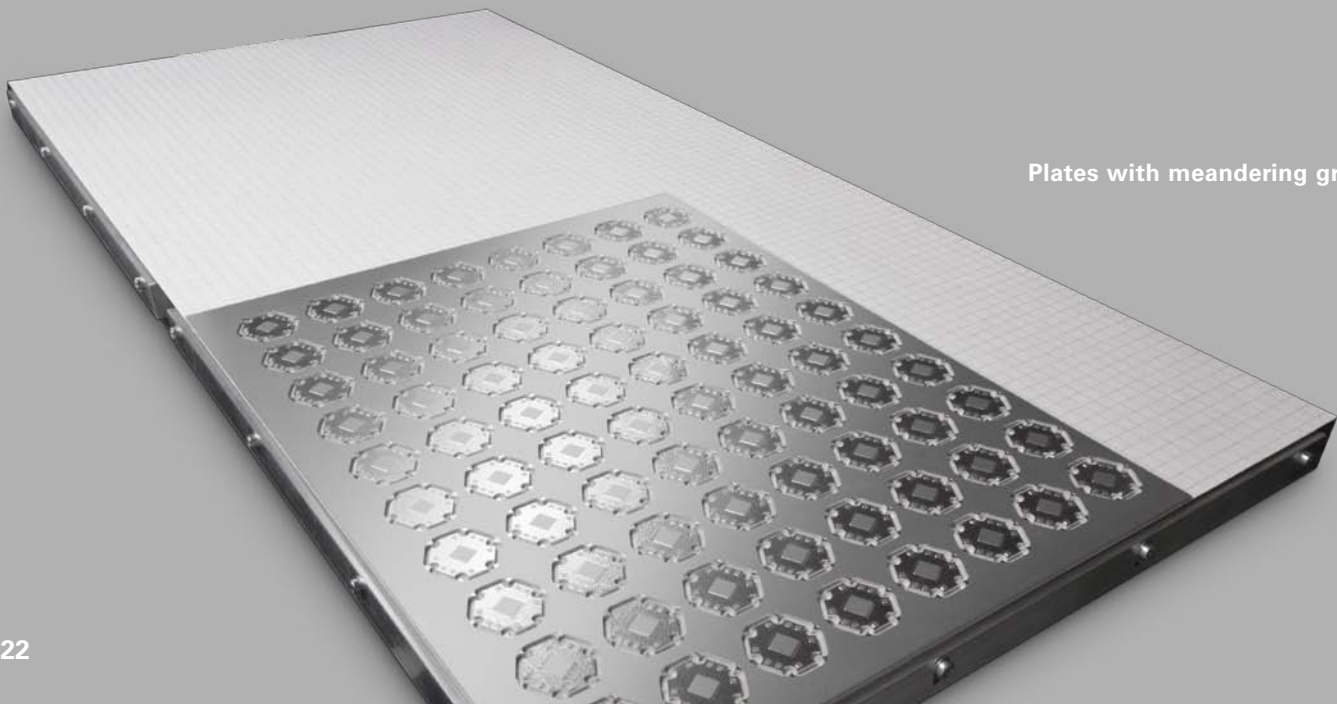
The new "VacuCard++" even allows machining small and delicate workpieces due to its self-adhesive surface.

## Advantages:

- Very short setup times
- Allows time-efficient optimum utilization machining
- Deformation-free and vibration-free clamping of thin plates
- Allows complete milling around workpieces and separating them

## Application:

- Clamping of sheet materials
- Clamping of flat housings
- Clamping of materials and shapes difficult to clamp otherwise



Plates with meandering grooves

DATRON

# Short-Stroke Clamping Elements

## One-handed fast setup!

Brilliantly simple to use with the light touch of a button, yet they boast clamping forces of up to 750 N. DATRON's short-stroke clamping elements can be used wherever high flexibility, ease of use and short setup times are required. The clamping elements are designed for operation on a T-slot plate, but can also be used in a stationary manner.



## Short-Stroke Clamping Elements Overview

### KSE-AS

Short-stroke clamping element for automatic clamping operation

#### Advantages:

- Automatic opening and closing
- Fast changeover
- Adjustable clamping pressure
- Compact design

#### Application:

- Flexible clamping of different workpieces
- Mass production



### KSE-PH

Pneumatic-hydraulic short-stroke clamping elements

#### Advantages:

- One-handed operation
- Fast changeover
- Adjustable clamping pressure
- Compact design

#### Application:

- Flexible clamping of different workpieces
- Batch production



# DATRON Sensor XYZ

Awesome in every dimension

The XYZ sensor is a three-dimensional touch sensor. With its help you can considerably reduce setup times of your milling machine. You increase accuracy and reliability when referencing your workpiece.

By using the XYZ sensor, your production attains higher cost-effectiveness. Time-consuming setups are something of the past. The special feature is automatic compensation, even height tolerances of materials, for example for perfect bevels even of large components, precision depth-machining, and much more.

It is amazing how easy machining of some components can get with measuring sensor.

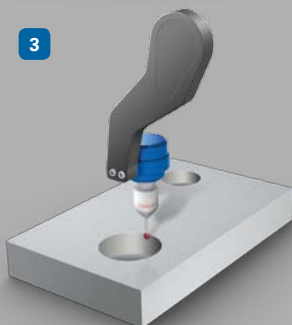
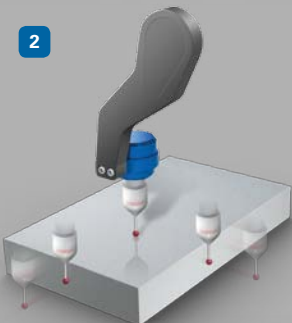
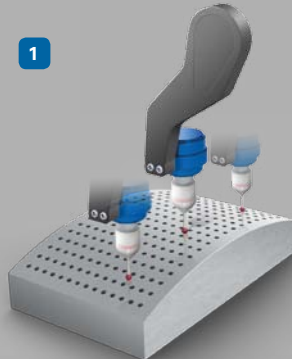


## How it works:

Just swing it into the machining area to increase production quality within seconds or to check dimensional accuracy: The XYZ sensor allows you to consistently optimise your production.

### 1 Material surfaces

The surface of the material is measured by grid scanning. The altitude profile created this way is corrected immediately by the CNC programme or the engraving programme. Navigate away from any uncertainties quickly, easily and comfortably.



### 2 Corners and edges

The edge of the material or the height of the workpiece can be calculated precisely with just one measurement. Three measurements allow determining both the height of the material and the exact position of a rectangular edge of a workpiece.

#### Advantage:

The determination of reference points on workpieces is achieved much more accurately with the XYZ sensor and within a fraction of the time of conventional methods.

### 3 Centres of workpieces

The centres of circular or rectangular islands or cut-outs can be determined automatically.

#### Advantage:

The centre of the workpiece can be precisely determined within just a few seconds, without needing long setup times. For example, by measuring two holes drilled for reference, a non-angular clamping can be compensated by rotating the coordinate system.



# DATRON

## Cooling/lubrication systems

DATRON minimum quantity cooling lubrication systems are the result of years of application experience. Depending on the cooling medium, there are minimal residues or none at all. No cleaning, no degreasing: a great advantage for many applications.

### DATRON EK-M cooling/lubrication system

This minimum quantity cooling/lubrication system can be used with different coolants/lubricants and is designed for reliable and reproducible results in milling and engraving processes with particularly small amounts of fluid.

There are three different spray head variants available for this system:

#### EK-VM-R

The circular spray head for HSK-E 25 spindles has four nozzles and is used in connection with CleanCut and machines with 11-fold tool changer.



#### EK-VM-4+

Spray head with four adjustable nozzles and bundled jet. It can be used for both spindles with HSK or direct shank clamping.



### DATRON EK-D cooling/lubrication system

This cooling/lubrication system for ethanol is suitable for spindles with direct shank clamping. Ethanol is sprayed through two nozzles onto the workpiece and the tool. The heat energy generated during milling is withdrawn by the evaporation process. In addition, ethanol lubricates the flute of the tool, thus increasing its service life. Cleaning the workpieces after machining is eliminated due to the complete evaporation of ethanol.



DATRON

# CNC High Frequency spindles

Precision in the micron-range, speeds up to 60,000 rpm

DATRON offers the right spindle for every need: from ultra-powerful, precision high-speed spindles to robust and cost-effective "workhorses". High quality, precision and durability are common features of all DATRON high-frequency spindles.

## PowerS

Powerful and extremely precise high-frequency spindle with HKS-E tool holder. For highest quality with high cutting performance. 3.0 kW at up to 40,000 rpm.

## HighS

This universal spindle for high-speed milling, drilling and engraving is available in three different versions:

**HighS L0.6** with 0.6 kW and up to 60,000 rpm, direct shank clamping, air cooling through spindle insert

**HighS M1.8** with 1.8 kW at up to 48,000 rpm; HSK-E 25 tool insert

**HighS H2.0** with 2.0 kW at up to 60,000 rpm; direct shank clamping

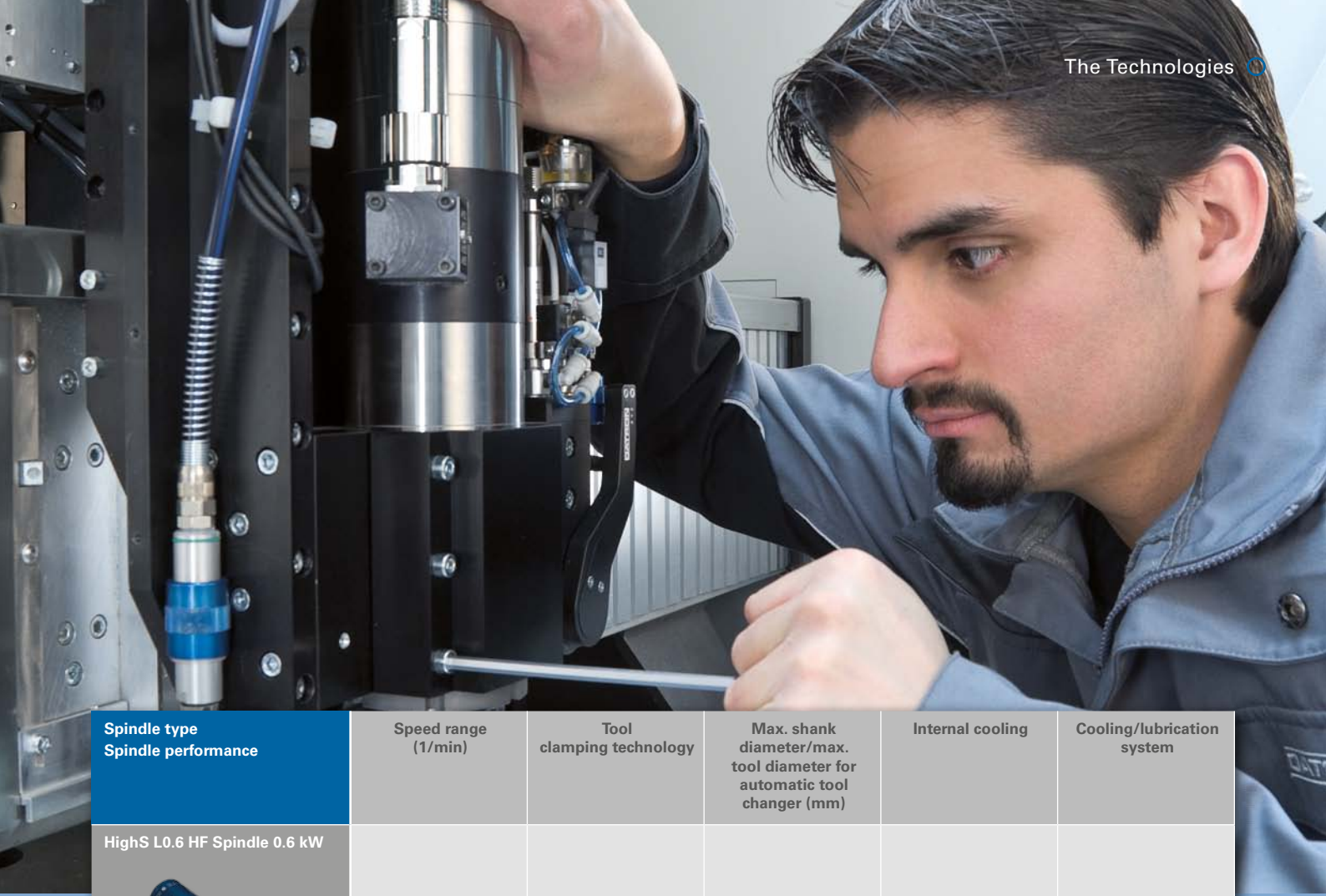
## EcoS

A particularly robust and efficient high-frequency spindle with direct shank clamping and automatic tool changer. Speeds up to 28,800 rpm with 1.2 kW power.

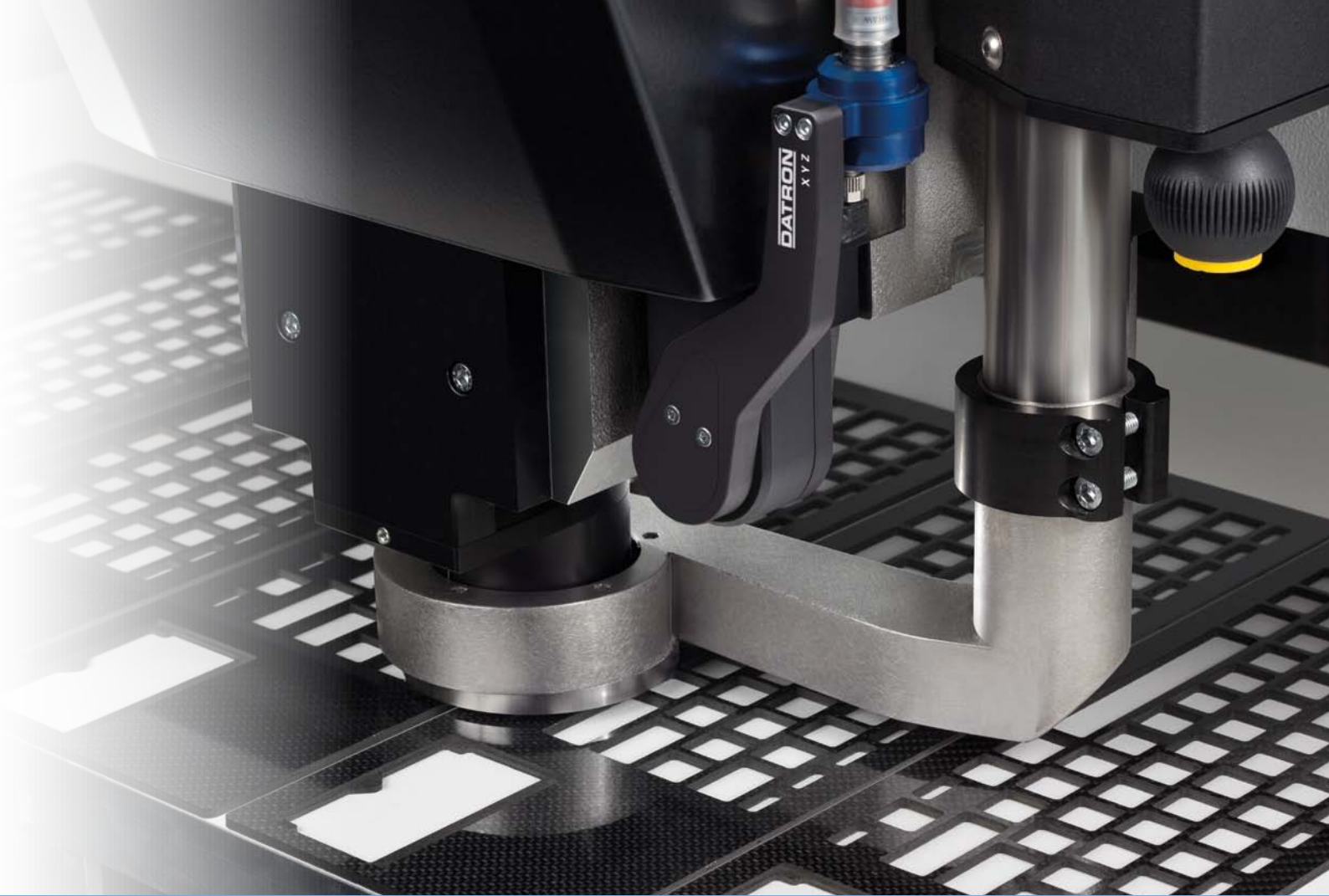
The expert selection of the appropriate spindle for your particular application is a particularly important point when configuring your milling machine.

Our experts will advise you on the spindle that is the most efficient solution for you.





Spindle type Spindle performance	Speed range (1/min)	Tool clamping technology	Max. shank diameter/max. tool diameter for automatic tool changer (mm)	Internal cooling	Cooling/lubrication system
<b>HighS L0.6 HF Spindle 0.6 kW</b> 	6,000 - 60,000	Direct shank clamping	8/14	Air	DATRON cooling lubrication system
<b>EcoS P1.2 HF Spindle 1.2 kW</b> 	5,000 - 28,800	Direct shank clamping	8/14	Air	DATRON cooling lubrication system
<b>HighS H2.0 HF Spindle 2.0 kW</b> 	6,000 - 60,000	Direct shank clamping	8/14	Liquid cooling	DATRON cooling lubrication system
<b>HighS M1.8 HF Spindle 1.8 kW</b> 	5,000 - 48,000	HSK-E 25	10/20	Liquid cooling	Minimum quantity cooling lubrication systems 5 l/9 l with filling level sensor
<b>PowerS Synchro 3.0 HF Spindle 3.0 kW</b> 	1,000 - 40,000	HSK-E 25	10/20	Liquid cooling	Minimum quantity cooling lubrication systems 5 l/9 l with filling level sensor



## DATRON CleanCut

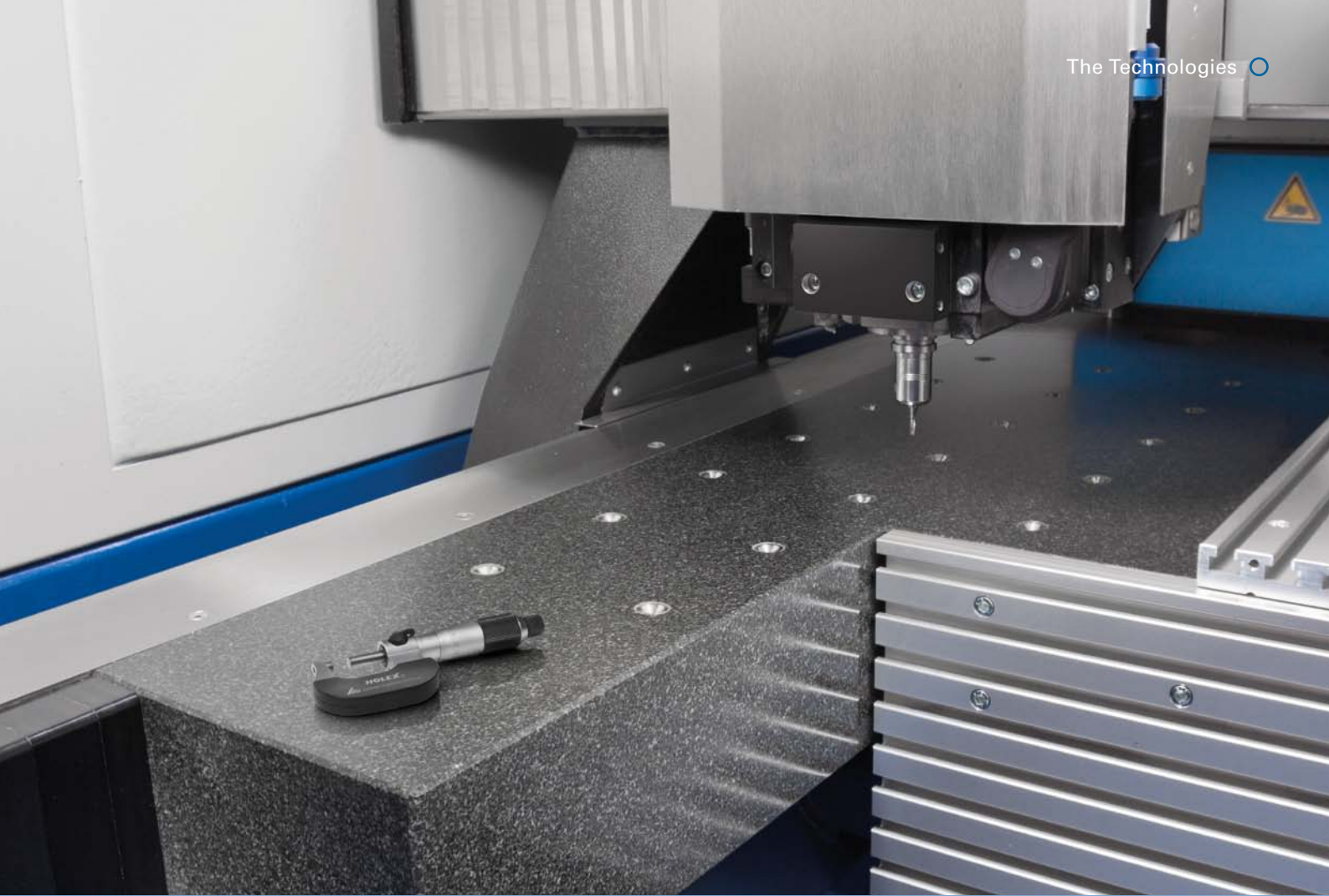
Save time and work cleanly:  
the CleanCut suction system is highly effective.

DATRON's CleanCut system provides highly effective chip suction. By means of this suction technology especially developed for plate-machining, almost chip-free working is achieved. Time-consuming machine cleaning is no longer necessary.

Perfect for sensitive surfaces: chips are vacuumed off without any contact. Automatic extension and retraction of the suction head represent a further saving of time.

### Properties:

- Programme-controlled swinging in and out
- Precise adjustment of surface distance
- Contact-free suction
- Compatible with tool-changing station and XYZ sensor
- Automatic swinging in and out with parking function activated
- Available for spindles with direct-shank and HSK-E 25 inserts
- Possibility of minimum quantity lubrication



## DATRON Highly Dynamic with Optimum Stiffness

DATRON CNC milling machines operate with high-speed milling technology (HSC - High Speed Cutting). Their high spindle speeds of up to 60,000 rpm with a highly dynamic machine control and their high feed rates, allow achieving excellent surface quality and shorter production times. Due to their high spindle speeds, DATRON milling machines reach in many cases, 5 to 10 times higher cutting speeds than conventional milling machines.

Their high-quality steel structure designed for speed and stiffness, combined with a granite or polymer concrete worktable, allows optimum vibration damping leading to optimum milling results.

- Very high cutting performance with the smallest tools by means of high-speed precision spindles with up to 60,000 rpm and 0.6 kW to 3.0 kW output
- Stiff, vibration-free design of DATRON machines due to reinforced polymer concrete or granite worktables allows excellent surface finishes when machining
- High precision due to high-quality linear guides, ball screw spindles, HSK-E 25 tool inserts (optional) and precision-crafted structural elements

# DATRON CNC milling tools



## Profitable Milling, Drilling and Engraving

DATRON has developed and delivered solid carbide tools of the highest quality level for more than 20 years. As a manufacturer of high-quality CNC milling, drilling and engraving machines, we have always placed special emphasis on cutting technology.

The technological design and the quality of CNC tools largely determine the cost-effectiveness and quality of CNC machining.

This catalogue provides you with an overview of our current product range. As the result of our own development and trials, as well as our customers' experiences, we are able to offer tools especially optimised for high-speed machining.



### Precision:

- Drilling from 0.1 mm
- Milling from 0.2 mm
- Thread milling from M1



### Quality made in Germany:

- Development
- Testing
- Production



### Economy:

- Max. cutting performance
- Max. lifetime
- Max. process safety

## Steel and other hard materials

## Wear-resistant

Stable cutting geometry and high-strength coatings guarantee cost-effective durability when machining hard materials.

Micro two-flute end mills enable filigree machining, three- and four-flute end mills are appropriate for face-milling and contour-milling.

Four-flute ball nose end mills are perfect for creating 3D freeform surfaces.



## Milling Tools for Aluminium



## High Performance

High cutting performance, quiet operation and smooth surfaces: milling tools such as the patented single flute end mill with counterbalanced cut, DATRON'S two flute end mills for smoothing and planing or our threading tools, support you in profitable machining of light metals.



## Milling Tools for Plastics/Composites/Foams



## Perfect Surfaces

Due to optimal chip removal, extremely fast feed rates without melting and burr-forming are also possible with plastics.

The generation of single flute end mills with polish grinding for machining plastics, allows highest-quality surface-finishing.

With DATRON's special tools for foam machining, excellent surfaces and sharp edges can be manufactured in short processing time. A particular unique feature is chamfering workpieces in a single step!



# HSCPro Control System

Easy to learn – highly productive

The HSCPro control technology, especially developed by DATRON, is the basis for the high performance of DATRON CNC milling machines.

Due to its high-performance fieldbus connection it allows imaging of the most complex machining procedures and offers other strengths:

- Powerful path processing/planning
- High-speed data processing rate up to 8,000 records per second
- High-performance control computer
- Drive amplifier from renowned manufacturers
- Brushless servo motors

The DATRON HSCPro control system is extremely powerful yet easy to use. This is achieved by a clear DATRON Windows®-based user interface and programming with plain text commands. The menu navigation is intuitive so that even complex applications can be programmed easily.

Multiple macro commands are available for demanding milling, drilling and engraving applications. Likewise, existing library functions can be used or new ones can be created by the operator. CAD interfaces allow the use of already existing data.





## HSCPro gives you maximum machine performance

### HSCPro – Easy to use:

- Easy to learn intuitive menu navigation
- Fast operation by means of DATRON shortcuts
- Simple programming of powerful macro commands

### Numerous functions:

- Many milling cycles come pre-configured (e. g. pockets, holes, threads, conical countersinks)
- Continuous expansion through application-specific macros possible
- Protected areas as collision protection for clamping devices
- Different measurement cycles to calibrate the workpiece (including partial measurement field)
- Programme-controlled vacuum technology
- PerfectCut contour smoothing filter

- Pre-calculation of the machining time
- Powerful engraving commands
- Extensive font libraries
- Graphical representation of the milling machining paths

### Maximum compatibility:

- Interfaces with all common CAD/CAM systems
- Import of DIN/ISO programming codes (DIW 66025)
- Import of HPGL, drilling data and CL-Print

### User interface HSCPro v9

- 1 Navigation with keyboard shortcuts for fast selection of machine functions.
- 2 Clear view of the machine status by means of a handsome representation
  - Position of the axes
  - Tool information
  - Spindle data
  - Cooling-lubricating system, etc.
- 3 Different operating modes such as editor, simulation, fast setting over keyboard shortcuts.



# PerfectCut

Fast, precise and contour accurate HSC milling for excellent surface quality

To achieve ideal reproductions of most complex geometries in HSC milling, DATRON has invented the surface smoothing package PerfectCut. With PerfectCut your DATRON M10 Pro, M8Cube and C5 achieve utmost performance levels and machine perfect surfaces and contours without the need for post-processing – enhancing your productivity!



## Production increase



You achieve high-quality milling results faster

- Significant improvement of manufacturing quality at shorter machine run times
- Less optimisation efforts when programming
- No reworking needed usually

## Better surface quality in a shorter time

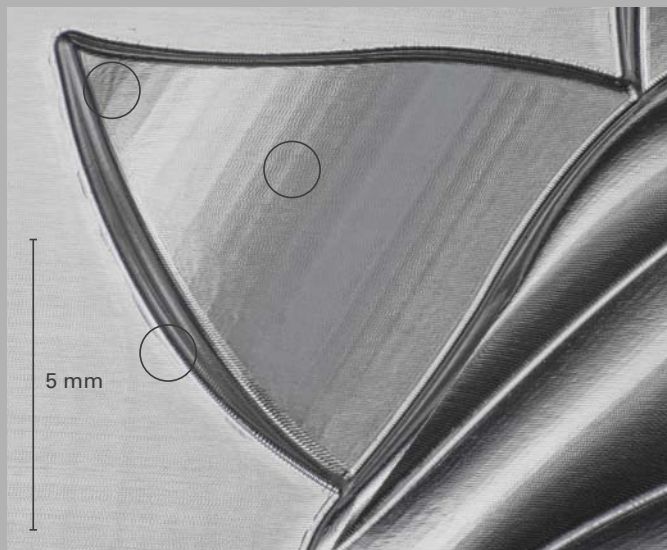


Achievement of better surface finish of workpieces within the same or shorter production time

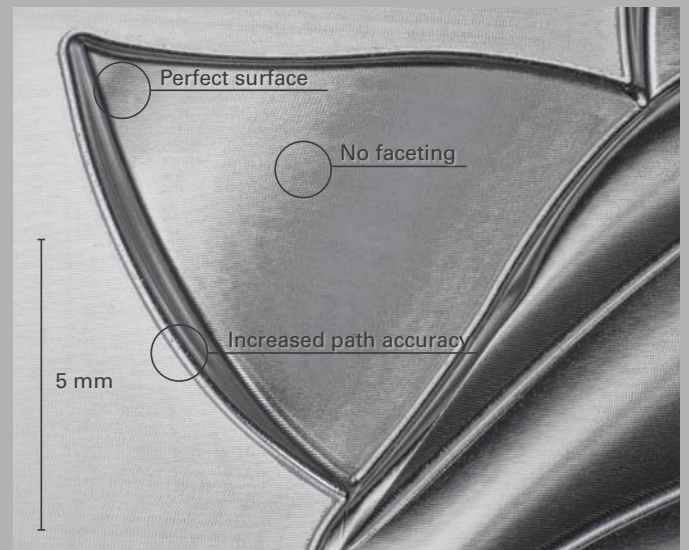
- Increased path accuracy
- No faceting
- Perfect surface



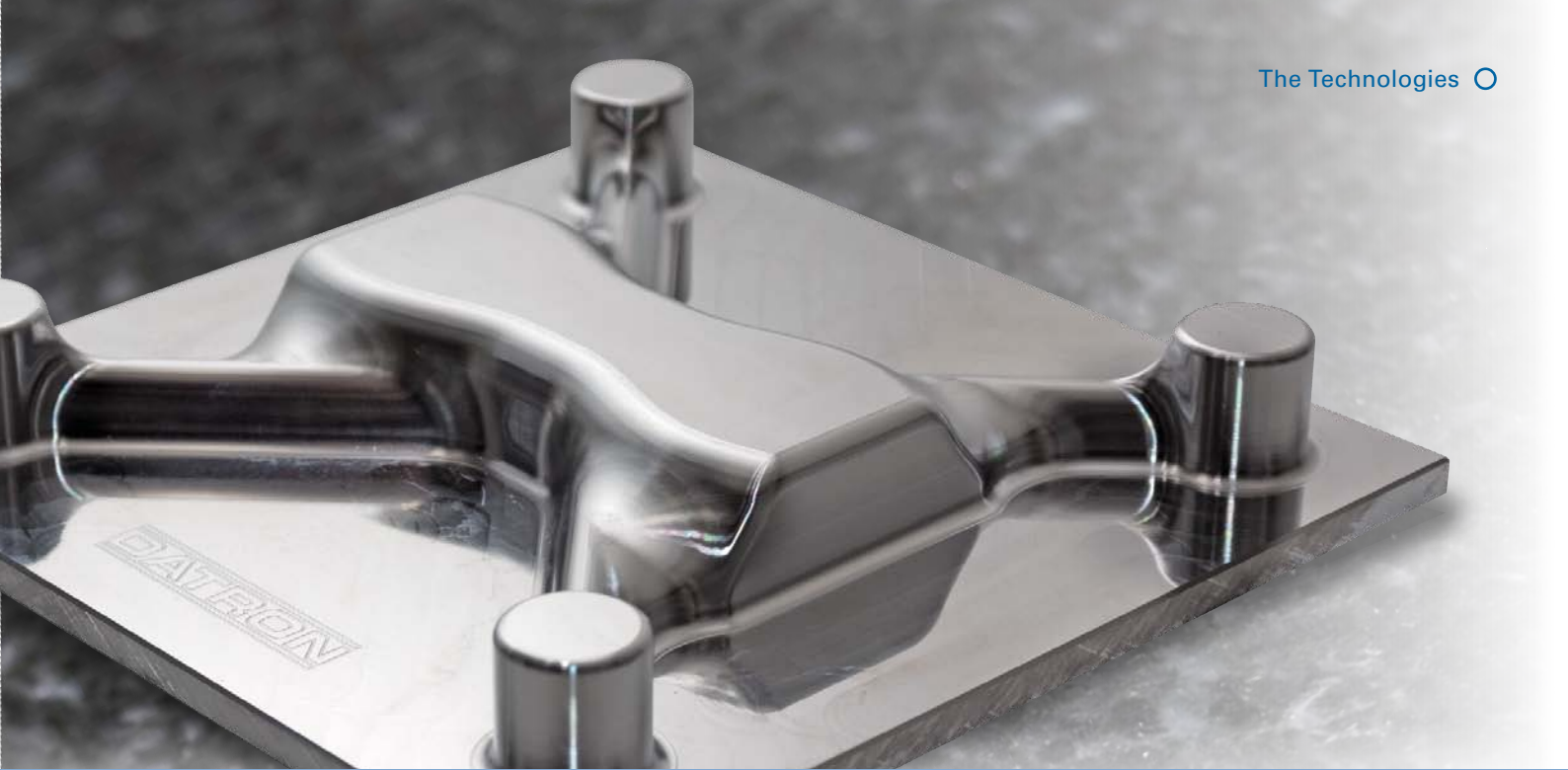
Original size



Before



After



### Your lead particularly in micromachining



You can mill even the smallest free-form surfaces and complex geometries and get perfect results

- Very high surface quality with all materials
- Fast processing with very short segment lengths
- Finest NC blocks with maximum feed rates

### Perfect results, faster



Your productivity is taken to new heights

- Fast programming
- Fast calculation
- Fast production

### Your machine is protected



Your machine stays „fit“ longer, even at high-volume production

- Less stress on all mechanic parts (especially the spindle) due to smooth running
- Higher capacity while protecting resources
- Increased end mill durability



## DATRON Customer Service

**From installation to many years of product support:  
You can count on us!**

DATRON guarantees maximum effectiveness in the operation of the machines, even many years after purchase – worldwide! By means of practical instruction and training, you will benefit from the full potential of our machines, right from the start.

The latest diagnostic tools and the in-depth expertise of our staff ensure smooth running of your production.

Our proven spare parts service and our customer-optimised maintenance programme minimize downtimes significantly. When you purchase a DATRON system, you receive much more than just a machine with controls: you get a team of experts that fully supports you!

**For more information about our Customer Service, please visit:**

**[www.service.datron.de](http://www.service.datron.de)**

## Decentralised

We are represented wherever we are needed. The local service team of our representatives abroad is at your disposal. Closeness saves time and money: for this reason, DATRON offers several service centres in Germany and worldwide at many of our more than 20 representative offices and agents.



## Cost-effective

Teleservices, e-Messenger, remote maintenance: we offer the latest information technologies for the fastest possible diagnoses and cost effective service.



## Friendly and Reliable

Our hotline will help you to find solutions and solve problems, even with software and programming issues. A comprehensive stock of spare parts guarantees shortest delivery times.



## Competence

Trained staff and many years of application experience and in-house practice guarantee the high quality of DATRON's service worldwide. As a result you get sound and competent advice and fast troubleshooting in the event of any malfunctioning problem.





## DATRON Technology Centre

Which machine is best for your manufacturing process depends on many individual parameters. Sound technical advice and the creation of samples are therefore part of our most important services. Accurate analysis of your production task forms the basis for our expert advice to optimise your entire production process.

### We offer:

- Creation of client-customised samples according to drawings (in printed or electronic form)
- Product demonstrations of our CNC milling machines
- Technological advice on CAD/CAM selection, clamping technology and DATRON's high-speed milling-tools

## DATRON

# Turnkey Solutions

With an extensive range of accessories and the knowledge of our experts, we optimise DATRON machine configuration for your production. Choose among several machine sizes and a range of powerful machining spindles.

The choice is yours: expand a particular machine with the appropriate clamping technology, the optimum cooling spray system, rotary axes, sensors, automation, CAD/CAM software packages and much more.

**We provide our customers with:**

- **Tailor-cut solutions**
- **Individual application advice**
- **Integrated clamping technology and automated solutions**
- **On-site installation and training**
- **Industry-leading service and support**



## Complete Process Chain

Profit from the profound knowledge of our experts in many fields of production technology. We will be happy to advise you in optimising all stages of the production chain: from CAD design to CAM data generation, clamping and measuring technology, tool and cooling technology up to the entire material flow.

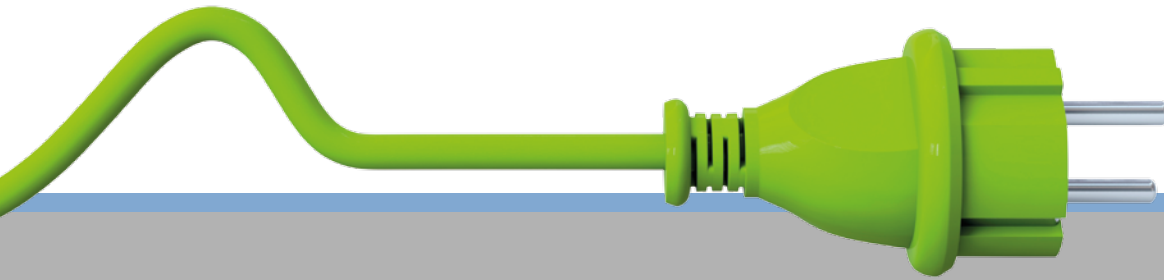
Tuning and optimising the entire process chain often leads to that crucial cost and quality advantage!



# DATRON

## Efficient and Energy-saving

Energy-efficient machines and the cost-effective use of resources play an increasingly important role in production processes. Through their innovative lightweight construction and energy-efficient drive technology, DATRON machines are more cost-effective already today. DATRON milling machines require on average less than 2.5 kW/h, even at high cutting capacities. The proprietary minimum quantity cooling lubrication system developed by DATRON also offers a highly cost-efficient and environmentally-friendly solution.



### **Saves energy:**

Very low power consumption by means of highest efficiency of all aggregates.



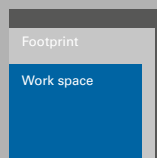
### **Saves money:**

Low-cost in purchase and operation.



### **Saves resources:**

Minimum quantity lubrication from 30 ml/hour. Minimal cleaning costs.



### **Saves space:**

Large machining table at extremely small footprint.





DATRON

## Innovative Technology “Made in Germany”

The name DATRON stands for high-quality machines and tools of the latest generation. In order to provide our customers with the best possible solution and to continuously improve our products, our experts are already working today on the production technologies of the future!

In close cooperation with universities and selected technology partners, DATRON pursues numerous research projects targeting more efficient and innovative manufacturing processes. Our innovation strength is proven by numerous patents; DATRON has been awarded three times the TOP 100 seal as one of the most innovative companies among the German small and mid-sized enterprises.

Quality and customer satisfaction are our top priority. “Made in Germany” is a key part of our product strategy. DATRON products are developed exclusively in Germany and made of extremely high-quality components.

With our certified total quality management system, we monitor and control the correct functioning of all processes, from product development over sales and delivery to service.

Reinforce your competitive lead even further with innovative DATRON products. Latest cutting technology, high quality and production efficiency are your key advantages.

# DATRON

## About us

### DATRON AG

**Dedicated staff and innovative products**

We develop, produce and distribute innovative CNC milling machines for the machining of future-oriented materials such as aluminium and composite materials, dental milling machines for the efficient processing of all common denture materials in dental laboratories and high-performance dispensing machines for industrial sealing and bonding applications.

Strong focus on customer value, a very good price-performance ratio, low power consumption and flexible adaptation through modular lightweight construction are a common feature of all our products. Standard solutions can be adapted to a very large extent to individual customer requirements.

Production and automation processes can be improved significantly due to components matched already during their development and the resulting superior technological features of DATRON's products. This not only leads to higher production quality, but also to lower manufacturing costs!

### DATRON's core products are:

#### **CNC milling machines for high-speed milling and 3D engraving**

Milling, drilling and engraving of aluminium, stainless steel, plastics and composites. High production speeds and results are achieved with speeds of up to 60,000 rpm.

We are the market leaders in Germany in the field of front panel and housing machining.

#### **Dental CAD/CAM milling/grinding machines**

The ultracompact 5-axis milling/grinding machines are suitable for machining all common dental materials. Equipped with 8-fold automation and 12-fold tool changer, DATRON's machines are the best choice for industrial dental mass production with high reliability, speed and precision.

#### **VDispenser®-Dispensing machines for precise and rapid bonding and sealing**

Our precise-volume dispensing technology is available and patented worldwide. Strong cost advantages result in mass production due to the high dispensing quality and speed of our systems.

#### **Tools for high-speed machining**

The quality of the tools is essential to determine machining results in high-speed machining. Our technological and advising expertise enables our customers to produce more economically than their competitors.

#### **Technical customer support**

Training, service hotline, maintenance, accessories and spare parts sales: Our professional service and expert advice in all fields lead to high customer satisfaction and to the "German Customer's Champion 2011" award.







We will be happy to provide you with detailed information at:  
**+49 (0) 61 51 - 14 19 - 0**



by E-mail:  
**info@datron.de**



or online at:  
**www.datron.de**